

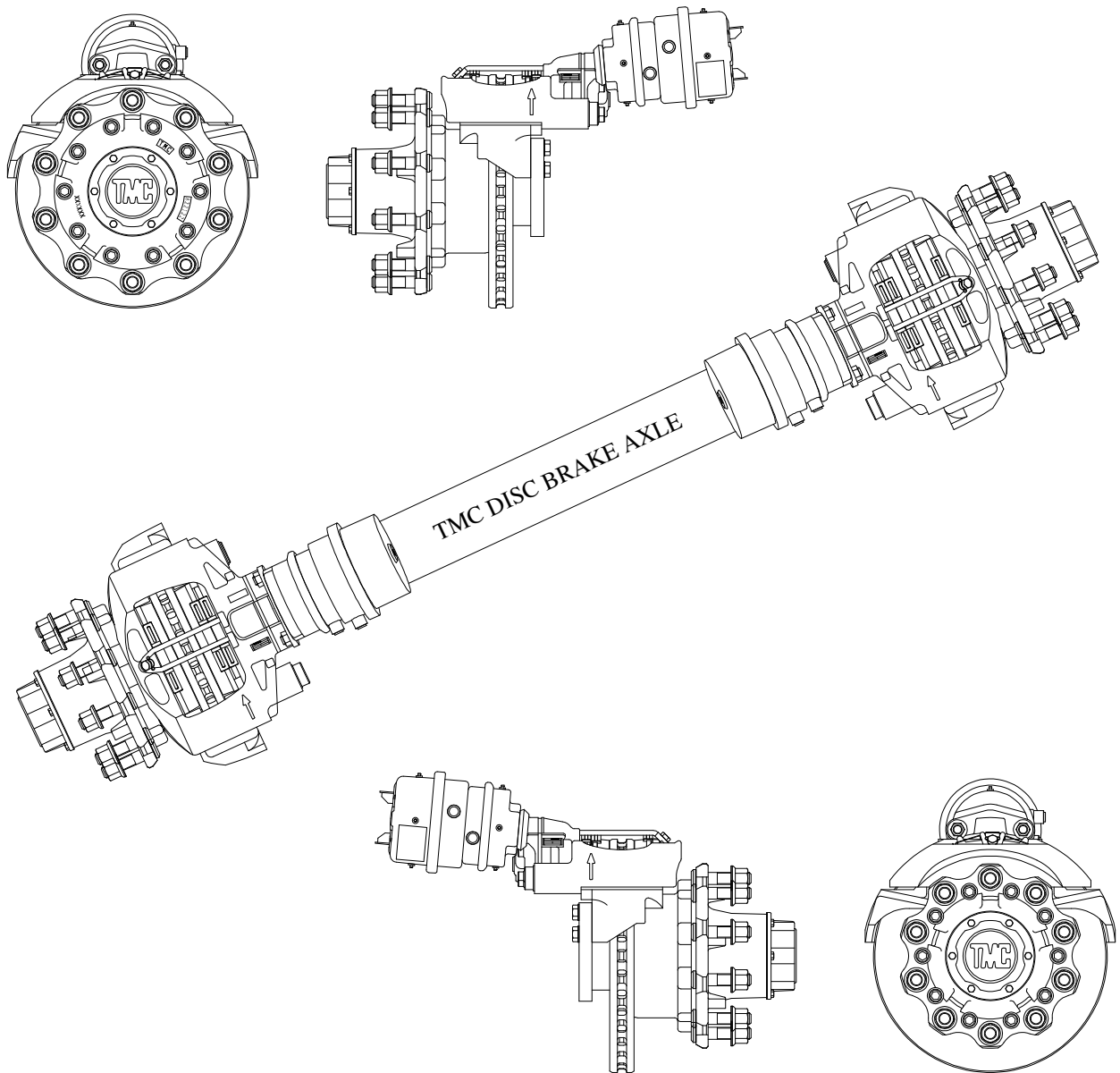

TMC Australia Pty Ltd
TMC Pan22 Disc Brake Axle Service Manual

TMC PAN 22 DISC BRAKE AXLE SERVICE MANUAL



TMC Australia Pty Ltd
78 Star Crescent
Hallam
Victoria 3803 Australia

Telephone: + 61 3 8786 3688
Facsimile: + 61 3 8786 3699
E-Mail: info@[tmcaus.com.au](mailto:info@tmcaus.com.au)
www.tmcaustralia.com.au

We Engineer Quality and Performance

RECOMMENDED SERVICE SCHEDULE

First Service 500 km or on Delivery:

- Check torque settings of all wheel nuts
- On delivery.
 - After all wheel changes.

After first 5000 Km:

Check and adjust all wheel bearings.

Every 5,000 km:

Check disc brake pad linings for wear.

Every 25,000 km:

With the axle end lifted rotate the wheels and determine if the wheel bearing needs adjustment.
Re adjust the wheel bearings as necessary.

Every 100,000 km:

Remove the hubcaps and inspect the wheel bearings and lubricant.
Replace the lubricant if it appears badly contaminated.
Re adjust the wheel bearings and re torque the axle lock nut.
Replace the hubcaps and ensure the correct amount of lubricant is in the hub end.
Check that the hubcap gasket is not damaged. Replace as necessary.
Check the axle for brake wear, check the rest of the axle components for wear or damage.
Repair, adjust or replace as necessary.

Every 300,000 km:

Remove wash and inspect the wheel bearings, replace as necessary.
When re assembling the wheel bearings ensure they are correctly lubricated and adjusted.
See TMC Australia's recommended wheel bearing adjustment procedures.

Note:

These are the minimum recommended service requirements, dependant on service conditions more frequent service and maintenance schedules may be required for correct operation of the trailer axle.

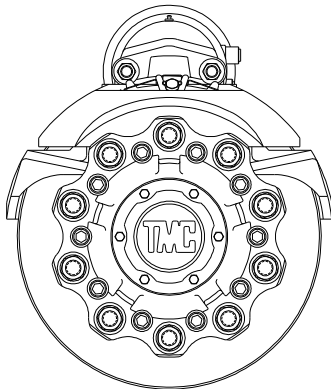

10 Stud x 285 pcd Hub
430 diameter disc brake

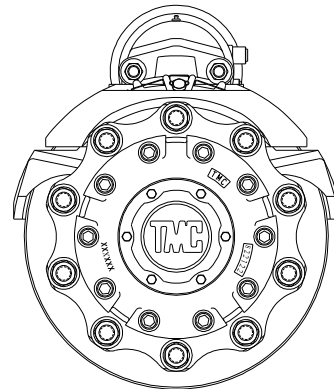

10 Stud x 335 pcd Hub
430 diameter disc brake

WHEEL BEARING ADJUSTMENT PROCEDURE

Double Axle Lock Nuts and Lock Washer – TN Wheel Bearings.

It is recommended that the wheel bearing in new axles (or whenever the wheel bearings are replaced in service) are adjusted after the first 5000 km. The wheel bearings should then be adjusted at 100,000 km intervals for the axle's service life. These are the minimum recommended service requirements, dependent on the service conditions more frequent service and maintenance schedules may be required for correct operation of the trailer axle.

Recommended wheel bearing adjustment procedure:

1. Ensure that the hub rotates freely in both directions. If any brake drag (binding) is felt temporarily back off the brake adjustment to ensure free rotation of the hub.
2. Rotate the hub in both directions and at the same time tighten the wheel bearing adjusting nut until a torque setting of 150/180 Nm is reached.
3. Then back off the adjusting nut six (6) holes, use the axle lock washer as a guide. Refit the axle lock washer, taking care that the wheel bearing adjustment is not disturbed. Fit the axle locknut and tighten to a torque of 290/320 Nm.

Check the bearing end float is 0.08mm to 0.20mm. Finally check that the hub rotates freely. If it does not rotate freely it may be necessary to redo the wheel bearing adjustment procedure. If Necessary, now re adjust the brakes.

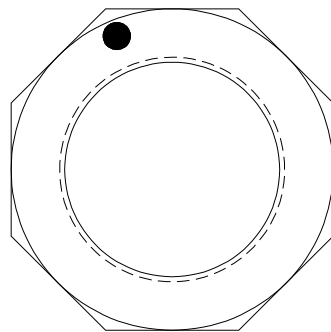

SPINDLE ADJUSTING NUT

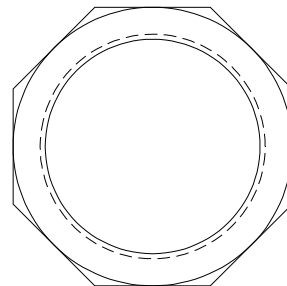

SPINDLE LOCK NUT

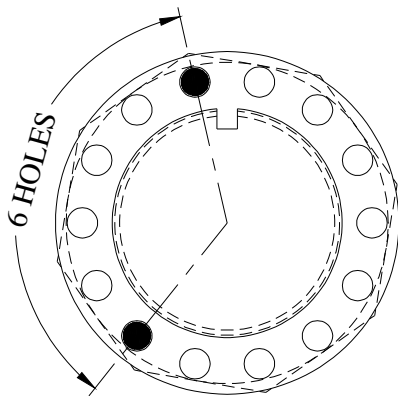

USE THE LOCK WASHER
AS A GUIDE, SLACKEN
BACK BY 6 HOLES

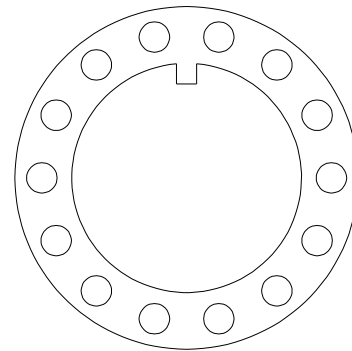

LOCK WASHER

**CHECK WHEEL BEARING END FLOAT IS 0.08mm TO 0.20mm.
RE ADJUST IF NECESSARY.**

WHEEL BEARING ADJUSTMENT CHECKING PROCEDURE

Double Axle Lock Nuts and Lock Washer – TN Preset Wheel Bearings.

It is recommended that the wheel bearing in new axles (or whenever the wheel bearings are replaced in service) are checked for end float after the first 5000 km. The wheel bearings should then be re checked for end float at 100,000 km intervals for the axle's service life. These are the minimum recommended service requirements, dependent on the service conditions more frequent service and maintenance schedules may be required for correct operation of the trailer axle.

Recommended wheel bearing end float checking procedure:

1. Ensure that the hub rotates freely in both directions. If any brake drag (binding) is felt temporarily back off the brake adjustment to ensure free rotation of the hub.
2. Rotate the hub in both directions and at the same time tighten the wheel bearing adjusting nut until a torque setting of 390/410 Nm is reached.
3. Fit the axle lock washer onto the axle.
Fit the axle locknut and tighten to a torque of 290/310 Nm.
4. Check the bearing end float is 0.08mm to 0.20mm. Finally check that the hub rotates freely. If it does not rotate freely it may be necessary to redo the wheel bearing tightening procedure.

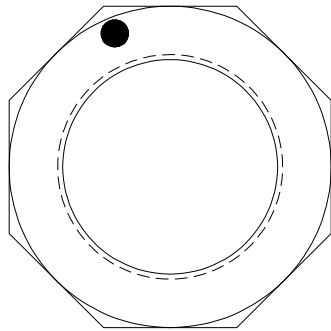

SPINDLE ADJUSTING NUT

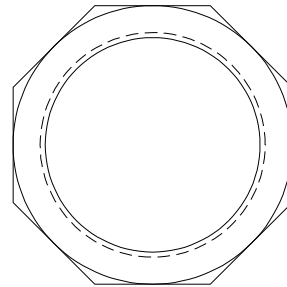

SPINDLE LOCK NUT

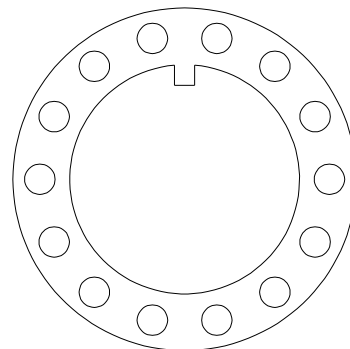

LOCK WASHER

Note:

Preset wheel bearings are unique bearings and cannot be mixed with other bearing types. When being serviced or replaced bearing cups and cones must be kept as pairs or replaced as full sets. The Preset bearing cups and cones must not be mixed.

AXLE HUB LUBRICATION

Grease Filled Hubs:

1. The wheel bearings must be fully packed with grease, it is recommended that a wheel bearing packer or suitable equipment is used to correctly pack the wheel bearings with grease.
2. Fill the hub cavity with grease as shown. The cavity is to be filled to a line running from inner bearing cup inner diameter to outer bearing cup inner diameter.
Caution: Do not overfill the hub cavity.
3. After the final assembly of the hub onto the axle end a smear of grease should be applied to the inside of the hubcap and over the axle spindle nut/s and lock washer.

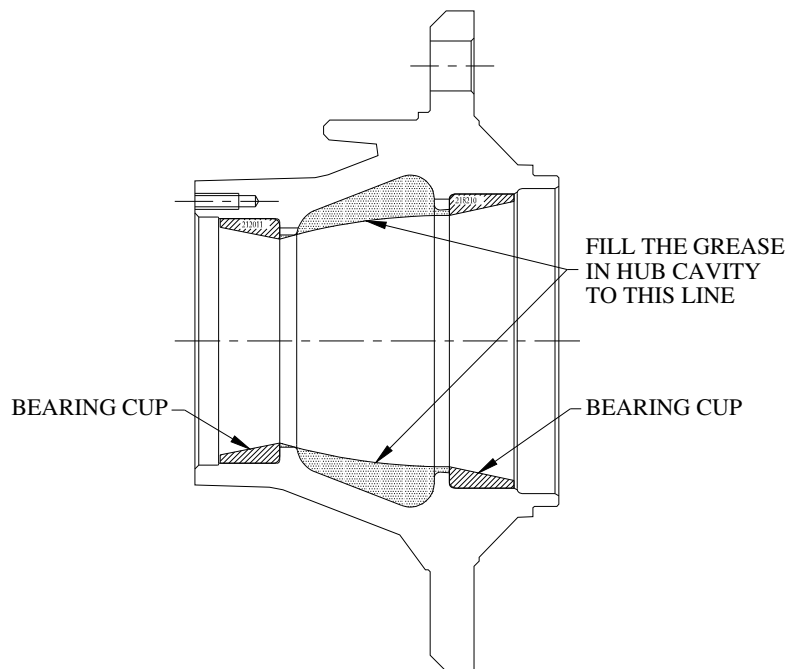

Oil Filled Hubs:

1. Remove the rubber plug or screwed plug from the hubcap so that the oil can be added to the hub.
2. Fill the hub with oil to the full level on the sight glass in the hubcap window.
3. Allow time for the oil to flow through the wheel bearings. Top up the hub with oil to the full mark. **Caution: Do not overfill the hub.**
4. Refit the rubber plug or screwed plug back into the hubcap. Check that the plug seals.

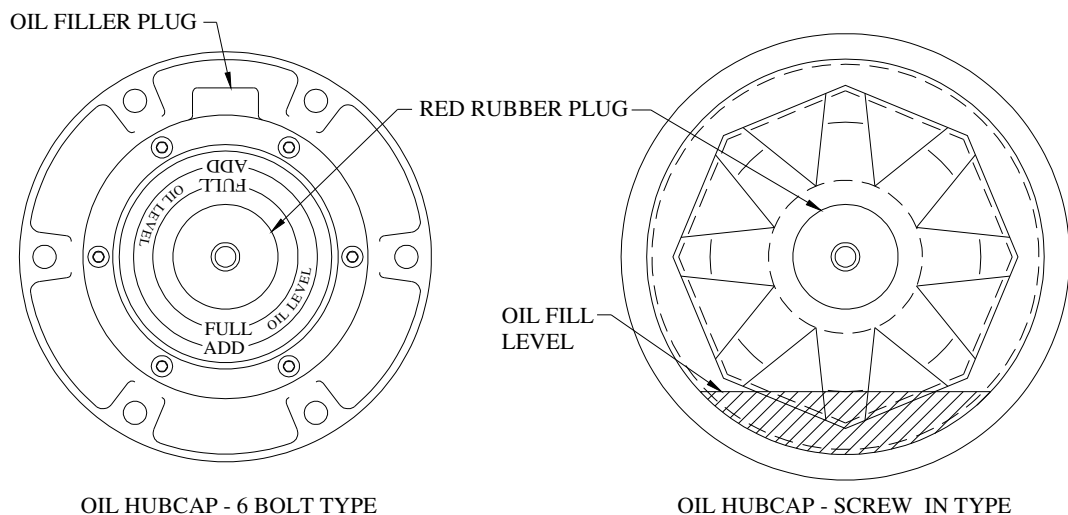

WHEEL BEARING LUBRICANTS

Grease: Mobil HP or an approved equivalent grease.
Oil: Mobil 85W/140 or an approved equivalent oil.

WELDING TO TMC AXLE BEAMS**Recommended welding procedures:**

1. Before any welding is conducted on the axle tube, the axle tube must be pre heated to 100 – 150⁰C locally at the area to which the welding is to be done.
Caution: Do not apply excessive heat to the axle tube.
2. All welding is to be applied to the axle tube as near as possible to the axles neutral axis. **Do not weld circumferentially around the axle tube.**
3. It is recommended that all welds are applied using small multiple fillet weld runs to achieve the desired finished weld fillet size.
4. All welds must be conducted using low hydrogen rods or an approved equivalent MIG process.

TORQUE SETTINGS CHART**Wheel nuts:**

M22 ISO wheel studs - 550/600 Nm.

Axle Hub to Disc Brake Rotor Studs:

M16 socket head studs grade 10.9 - 300/320 Nm.

Brake Caliper Mounting Bolts:

M16 Bolts grade 10.9 - 250/290 Nm.

Hub Cap Bolts:

M8 studs - 20/25 Nm.

5/16" UNC studs - 20/25 Nm.

It is recommended on assembly that for the hub to rotor studs (M16) that a small amount of Loctite 243 is applied to the threads and on the brake calliper mounting studs (M16) anti seize is applied to the threads.

Pan 22 Disc Brake Axle Spares Listing

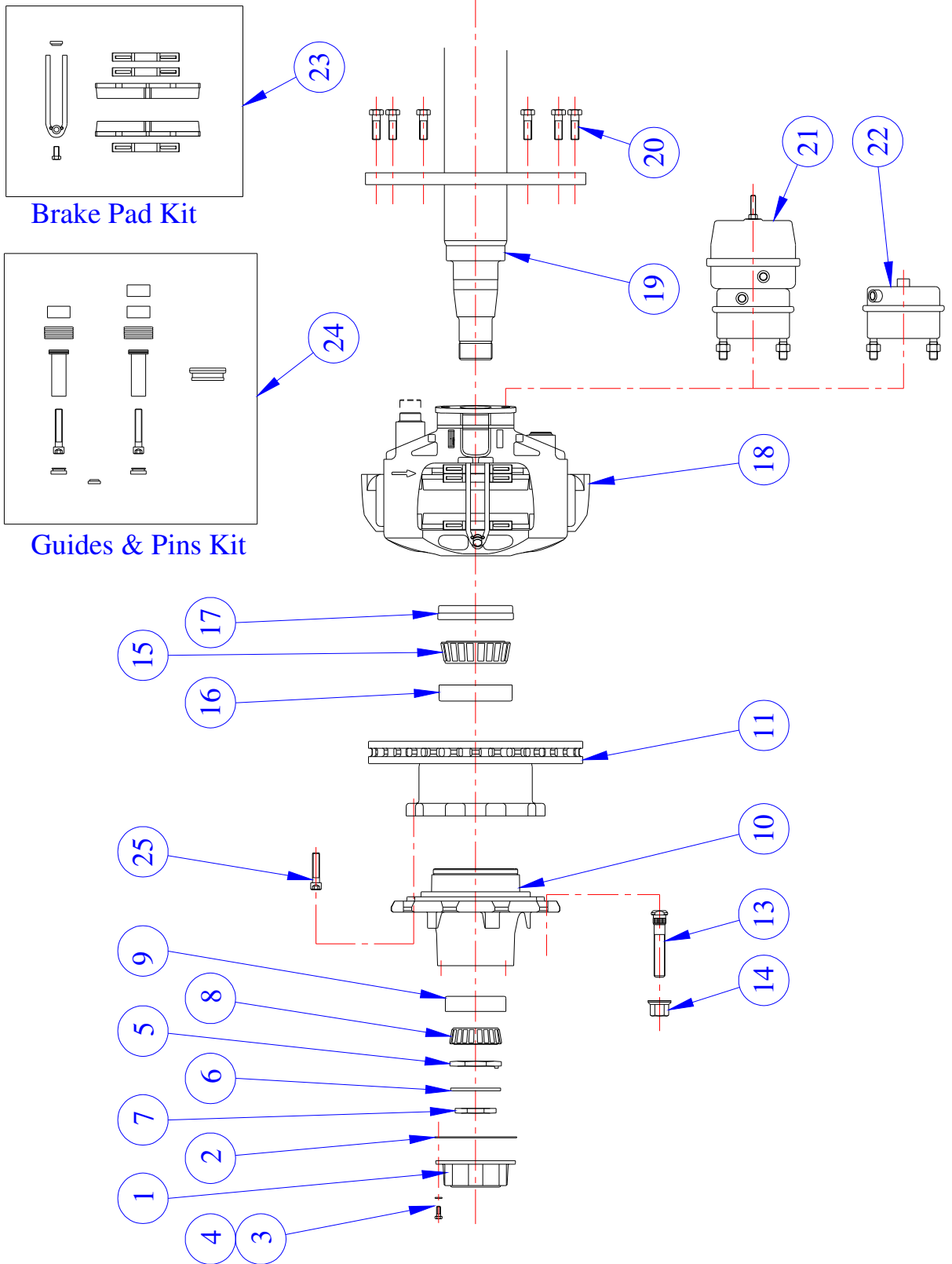



TMC Australia Pty Ltd

TMC Pan22 Disc Brake Axle Service Manual

Pan 22 Disc Brake Axle Spares Listing

Item	Part Number	Description
1	810146	Hubcap – grease
	810176	Hubcap – oil
2	810147	Hubcap gasket
3	9HBM08125025	Hubcap stud M8 x 25 long (steel hubs)
	9HB5/16UNC1.00	Hubcap stud 5/16” UNC x 1” long (aluminum hubs)
4	9SWM08	Hubcap spring washer
5	810124	Axle spindle adjusting nut
6	810123	Axle spindle lockwasher
7	810125	Axle spindle lock nut
8	81HM212049	Outer bearing cone
9	81HM212011	Outer bearing cup
10	822121	Hub 10 stud x 285 pcd
	822123	Hub 10 stud x 335 pcd
	822501	Hub aluminum preset 10 stud x 285 pcd
11	822201	Rotor – 430mm diameter – steel hubs
	822512	Rotor – 430mm diameter – aluminum hub new
	822502	Rotor – 430mm diameter – aluminum hub old
12	9SHM16200035	Hub to rotor bolt M16 x 35 long Gr 10.9
13	810144	Wheel stud M22 x 100 long
	810225	Wheel stud M22 x 115 long
14	820145	Wheel nut M22
15	81HM218248	Inner wheel bearing cone
16	81HM218210	Inner wheel bearing cup
17	810135	Hub seal
18	822211	Disc brake caliper assembly LH Pan 22
	822212	Disc brake caliper assembly RH Pan 22
19	822101	Axle beam assembly
20	9HBM16150050	Caliper attachment bolts M16 x 50 long Gr 10.9
21	820109	Brake chamber Type 16/24 universal
	820131	Brake chamber Type 16/16 universal
	820133	Brake chamber Type 12/16 universal
	820138	Brake chamber Type 14/16 universal
	820139	Brake chamber Type 14/24 universal
	820140	Brake chamber Type 20/16 universal
	820149	Brake chamber Type 20/24 universal
22	820132	Brake chamber Type 16 universal
	820134	Brake chamber Type 12 universal
	820135	Brake chamber Type 20 universal
	820136	Brake chamber Type 24 universal
	820137	Brake chamber Type 22 universal
23	822676	Brake pad set (per axle)
24	820738	Caliper guide pins and seals set (per axle)
	820736	Main piston and seal set with piston (per axle)