

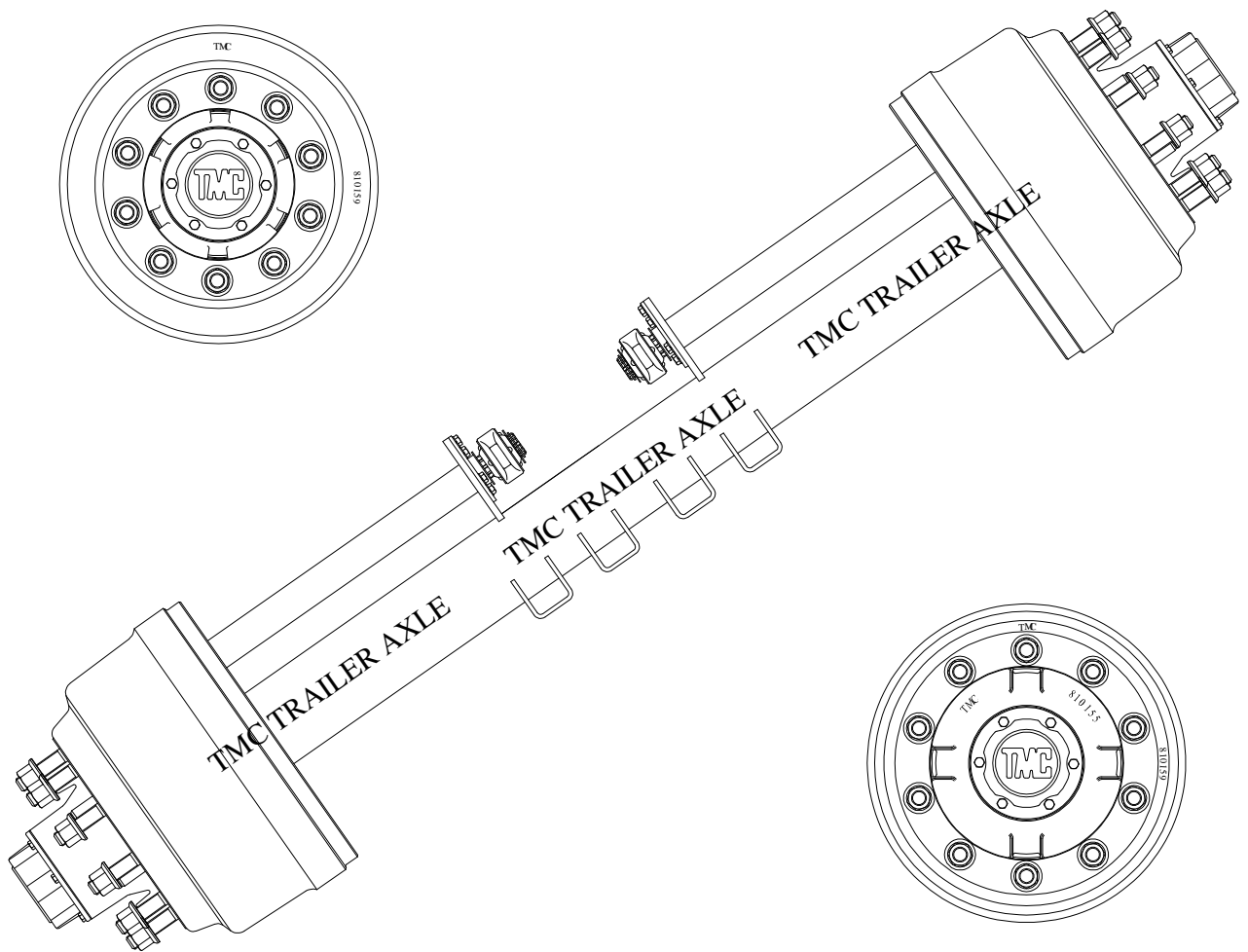

**TMC Australia Pty Ltd**

**TMC Trailer Axle Service Manual - Drum Brakes**

# **TMC TRAILER AXLE SERVICE MANUAL DRUM BRAKE AXLES**



TMC Australia Pty Ltd  
78 Star Crescent  
Hallam  
Victoria 3803 Australia

Telephone: + 61 3 8786 3688  
Facsimile: + 61 3 8786 3699  
E-Mail: [info@tmcaus.com.au](mailto:info@tmcaus.com.au)  
[www.tmcaustralia.com.au](http://www.tmcaustralia.com.au)

**We Engineer Quality and Performance**

**RECOMMENDED SERVICE SCHEDULE****First Service 500 km or on Delivery:**

- Check torque settings of all wheel nuts
- On delivery.
  - After all wheel changes.

**After first 5000 Km:**

Check and adjust all wheel bearings.

**Every 5,000 km:**

Check and adjust the brakes, check brake linings for wear.

**Every 25,000 km:**

Lubricate slack adjusters and camshaft bushings using an EP2 type grease or equivalent.  
With the axle end lifted rotate the wheels and determine if the wheel bearing's need adjustment.  
Re adjust the wheel bearings as necessary.

**Every 100,000 km:**

Remove the hubcaps and inspect the wheel bearings and lubricant.  
Replace the lubricant if it appears badly contaminated.  
Re adjust the wheel bearings and re torque the axle lock nut.  
Replace the hubcaps and ensure the correct amount of lubricant is in the hub end.  
Check that the hubcap gasket is not damaged. Replace as necessary.  
Check the axle for brake wear, check the rest of the axle components for wear or damage.  
Repair, adjust or replace as necessary.

**Every 300,000 km:**

Remove wash and inspect the wheel bearings, replace as necessary.  
When re assembling the wheel bearings ensure they are correctly lubricated and adjusted.  
See TMC Australia's recommended wheel bearing adjustment procedures.

**Note:**

These are the minimum recommended service requirements, dependant on service conditions more frequent service and maintenance schedules may be required for correct operation of the trailer axle.

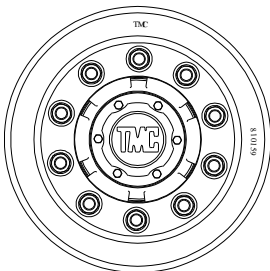

10 Stud x 285 pcd Hub  
420 x 180 Brake

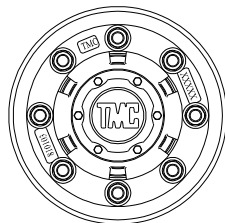

8 Stud x 275 pcd Hub  
335 x 210 Brake

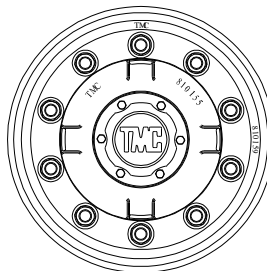

10 Stud x 335 pcd Hub  
420 x 180 Brake

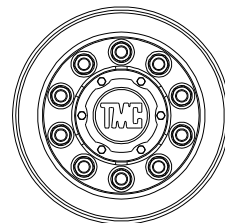

10 Stud x 225 pcd Hub  
335 x 210 Brake

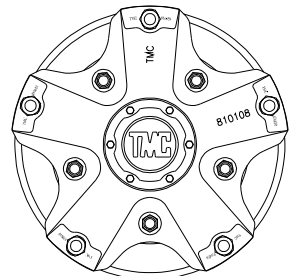

5 Spoke Spider Hub  
420 x 180 Brake

**WHEEL BEARING ADJUSTMENT PROCEDURE****Double Axle Lock Nuts and Lock Washer – TN Wheel Bearings.**

It is recommended that the wheel bearing in new axles (or whenever the wheel bearings are replaced in service) are adjusted after the first 5000 km. The wheel bearings should then be adjusted at 100,000 km intervals for the axle's service life. These are the minimum recommended service requirements, dependent on the service conditions more frequent service and maintenance schedules may be required for correct operation of the trailer axle.

**Recommended wheel bearing adjustment procedure:**

1. Ensure that the hub rotates freely in both directions. If any brake drag (binding) is felt temporarily back off the brake adjustment to ensure free rotation of the hub.
2. Rotate the hub in both directions and at the same time tighten the wheel bearing adjusting nut until a torque setting of 150/180 Nm is reached.
3. Then back off the adjusting nut six (6) holes, use the axle lock washer as a guide. Refit the axle lock washer, taking care that the wheel bearing adjustment is not disturbed. Fit the axle locknut and tighten to a torque of 290/320 Nm.

Check the bearing end float is 0.08mm to 0.20mm. Finally check that the hub rotates freely. If it does not rotate freely it may be necessary to redo the wheel bearing adjustment procedure. If Necessary, now re adjust the brakes.

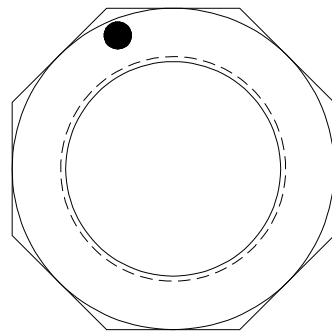

SPINDLE ADJUSTING NUT

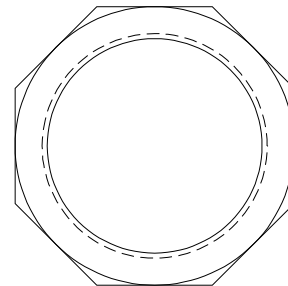

SPINDLE LOCK NUT

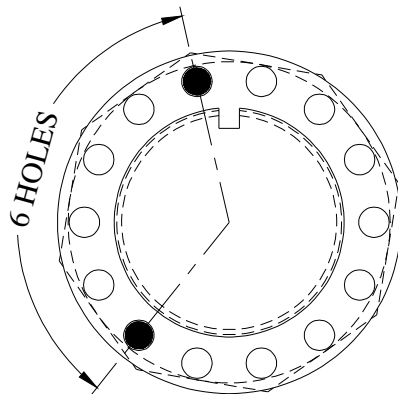

USE THE LOCK WASHER  
AS A GUIDE, SLACKEN  
BACK BY 6 HOLES

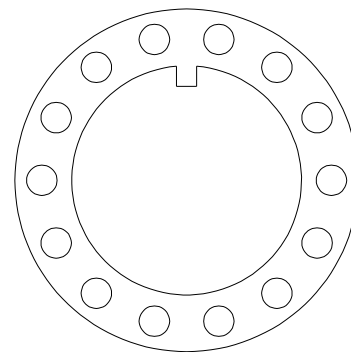

LOCK WASHER

**CHECK WHEEL BEARING END FLOAT IS 0.08mm TO 0.20mm.  
RE ADJUST IF NECESSARY.**

**WHEEL BEARING ADJUSTMENT CHECKING PROCEDURE****Double Axle Lock Nuts and Lock Washer – TN Preset Wheel Bearings.**

It is recommended that the wheel bearing in new axles (or whenever the wheel bearings are replaced in service) are checked for end float after the first 5000 km. The wheel bearings should then be re checked for end float at 100,000 km intervals for the axle's service life. These are the minimum recommended service requirements, dependent on the service conditions more frequent service and maintenance schedules may be required for correct operation of the trailer axle.

**Recommended wheel bearing end float checking procedure:**

1. Ensure that the hub rotates freely in both directions. If any brake drag (binding) is felt temporarily back off the brake adjustment to ensure free rotation of the hub.
2. Rotate the hub in both directions and at the same time tighten the wheel bearing adjusting nut until a torque setting of 390/410 Nm is reached.
3. Fit the axle lock washer onto the axle.  
Fit the axle locknut and tighten to a torque of 290/310 Nm.
4. Check the bearing end float is 0.08mm to 0.20mm. Finally check that the hub rotates freely. If it does not rotate freely it may be necessary to redo the wheel bearing tightening procedure.

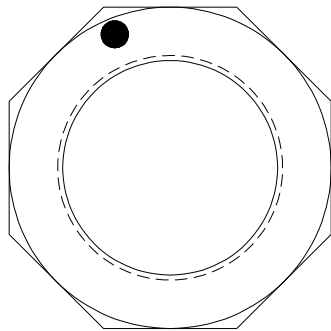

SPINDLE ADJUSTING NUT

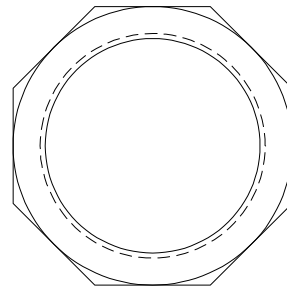

SPINDLE LOCK NUT

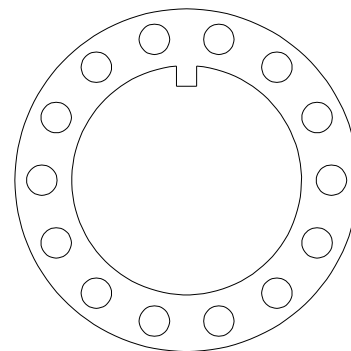

LOCK WASHER

**Note:**

**Preset wheel bearings are unique bearings and cannot be mixed with other bearing types. When being serviced or replaced bearing cups and cones must be kept as pairs or replaced as full sets. The Preset bearing cups and cones must not be mixed.**

**WHEEL BEARING ADJUSTMENT PROCEDURE****Castellated Axle Nut with Split Pin – TP (Parallel) Wheel Bearings.**

It is recommended that the wheel bearings in new axles (or whenever the wheel bearings are replaced in service) are adjusted after the first 5000 km. The wheel bearings should then be adjusted at 100,000 km intervals for the axle's service life. These are the minimum recommended service requirements, dependent on service conditions more frequent service and maintenance schedules may be required for correct operation of the trailer axle.

**Recommended wheel bearing adjustment procedure:**

1. Ensure that the hub rotates freely in both directions. If any brake drag (binding) is felt temporarily back off the brake adjustment to ensure free rotation of the hub.
2. Rotate the hub in both directions and at the same time tighten the axle adjusting nut (castellated) until a torque setting of 150/180 Nm is reached.
3. Then back off the axle adjusting nut approximately one eighth of a turn, using the axle adjusting nut as a guide. Refit the axle cotter (split) pin and lock in place. Take care that the wheel bearing adjustment is not disturbed.

Check the bearing end float is 0.08mm to 0.20mm. Finally check that the hub rotates freely. If it does not rotate freely it may be necessary to redo the wheel bearing adjustment procedure. If Necessary, now re adjust the brakes.

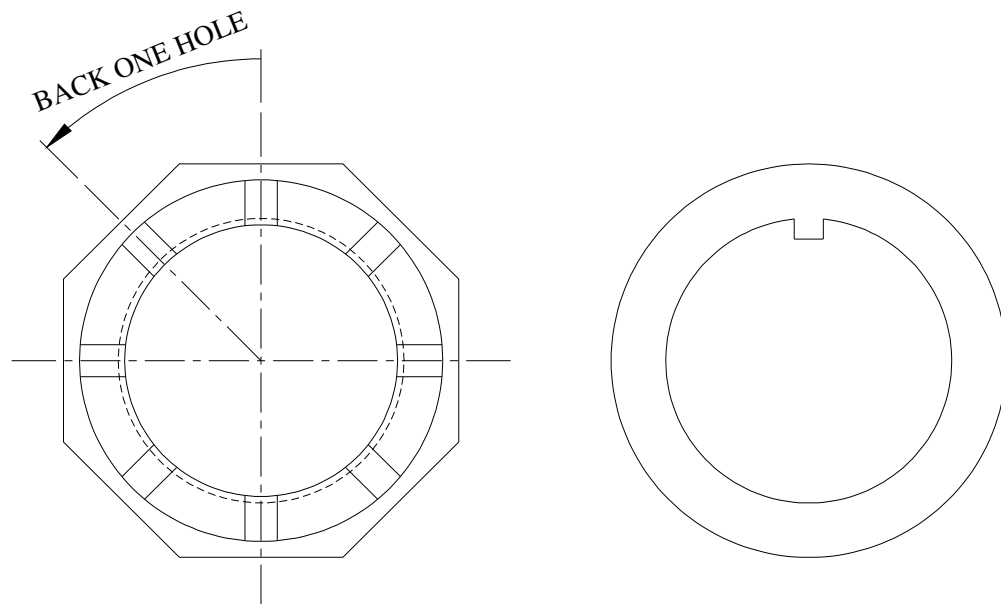

USE THE AXLE ADJUSTING NUT AS A GUIDE, SLACKEN BACK TO FIRST AVAILABLE SPLIT PIN HOLE.

BEARING TAB WASHER

**CHECK WHEEL BEARING END FLOAT IS 0.08mm TO 0.20mm.  
RE ADJUST IF NECESSARY.**

**BRAKE ADJUSTMENT – MANUAL SLACK ADJUSTERS**

‘S’ Cam brakes are adjusted by the manual slack adjusters fitted to the camshafts on the axle.

1. With the brakes released, adjust the slack adjuster until the brake linings contact the brake drum. This is done by rotating the 19mm hexagonal nut clockwise.
2. Adjust the 19mm hexagonal nut back one half turn or until the hub rotates freely with no brake drag evident.
3. Finally check that with the brakes released and applied that the angle between the brake chamber push rod and slack adjuster is greater than 90 degrees. The angle can be adjusted by screwing the push rod clevis backwards or forwards along the push rod thread to achieve the correct angle. When finished always check that the push rod clevis lock nut is tightened.

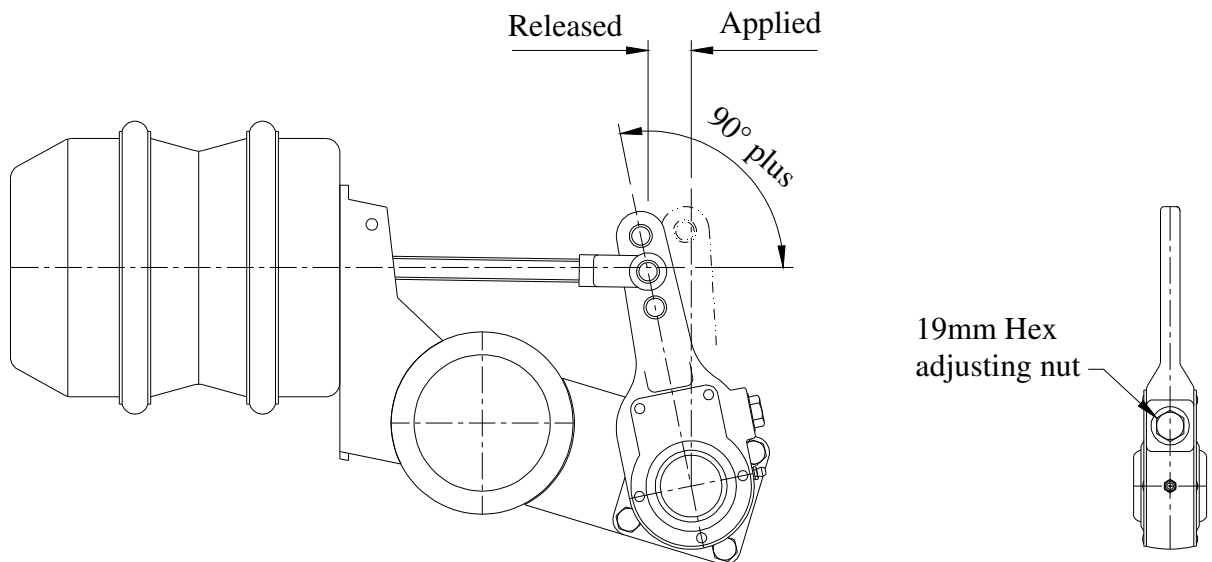
**BRAKE ADJUSTMENT - MANUAL SLACK ADJUSTER.****BRAKE ADJUSTMENT – AUTOMATIC SLACK ADJUSTERS**

‘S’ cam brakes fitted with automatic slack adjusters should require no manual adjustment after the initial installation on the axle or initial re adjustment of the brakes after brake relines. All automatic slack adjusters have a specific set up and installation procedure as specified by the automatic slack adjuster manufacturer. This procedure must be adhered to. If in doubt contact the manufacturer of the automatic slack adjusters or the manufacturer’s agent for these specific procedures.

Generally, automatic slack adjusters must be re adjusted similarly to the manual slack adjusters on initial installation or after brake relines.

**Caution: Please refer to the manufacturer’s recommendations.**

**AXLE HUB LUBRICATION****Grease Filled Hubs:**

1. The wheel bearings must be fully packed with grease, it is recommended that a wheel bearing packer or suitable equipment is used to correctly pack the wheel bearings with grease.
2. Fill the hub cavity with grease as shown. The cavity is to be filled to a line running from inner bearing cup inner diameter to outer bearing cup inner diameter.  
**Caution: Do not overfill the hub cavity.**
3. After the final assembly of the hub onto the axle end, a smear of grease should be applied to the inside of the hubcap and over the axle spindle nut/s and lock washer.

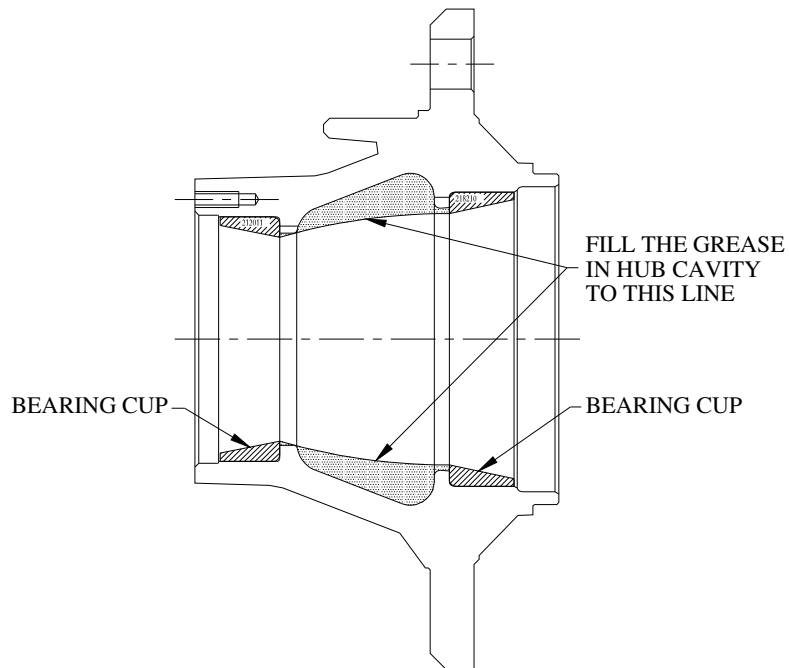
**Oil Filled Hubs:**

1. Remove the rubber plug or screwed plug from the hubcap so that the oil can be added to the hub.
2. Fill the hub with oil to the full level on the sight glass in the hubcap window.
3. Allow time for the oil to flow through the wheel bearings. Top up the hub with oil to the full mark. **Caution: Do not overfill the hub.**
4. Refit the rubber plug or screwed plug back into the hubcap. Check that the plug seals.

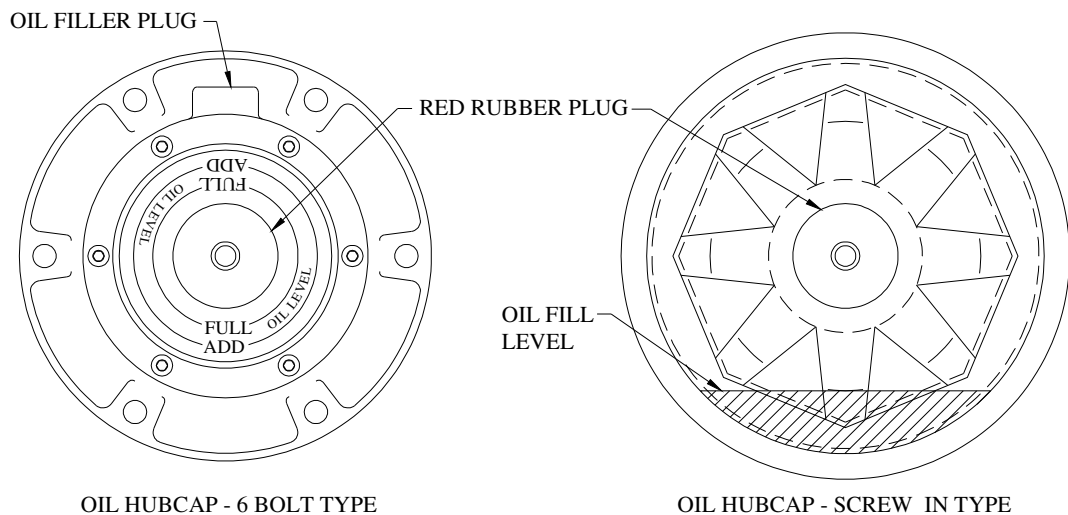



# TMC Australia Pty Ltd

## TMC Trailer Axle Service Manual - Drum Brakes

### WHEEL BEARING LUBRICANTS

**Grease:** Mobil HP or an approved equivalent grease.  
**Oil:** Mobil 85W/140 or an approved equivalent oil.

### WELDING TO TMC AXLE BEAMS

#### **Recommended welding procedures:**

1. Before any welding is conducted on the axle tube, the axle tube must be pre heated to 100 – 150<sup>0</sup>C locally at the area to which the welding is to be done.  
**Caution: Do not apply excessive heat to the axle tube.**
2. All welding is to be applied to the axle tube as near as possible to the axle's neutral axis. Do not weld circumferentially around the axle tube.
3. It is recommended that all welds are applied using small multiple fillet weld runs to achieve the desired finished weld fillet size.
4. All welds must be conducted using low hydrogen rods or an approved equivalent MIG process.

### TORQUE SETTINGS CHART

#### Wheel nuts:

**M22 ISO wheel studs** - 550/600 Nm.  
**3/4" Unc Spider wheel studs** - 200/260 Nm.

#### Inner Camshaft Bracket Bolts:

**M10 bolt and nut** - 30/35 Nm.

#### Dust Cover Bolts:

**M8 studs** - 20/25 Nm.

#### Hub Cap Bolts:

**M8 studs** - 20/25 Nm.  
**5/16" Unc studs** - 20/25 Nm.

### SPARE PARTS - AXLE MODELS PFRD-225-167 and PFRD-245-167

Axles with 420mm diameter x 180mm wide brakes (16.5" x 7").

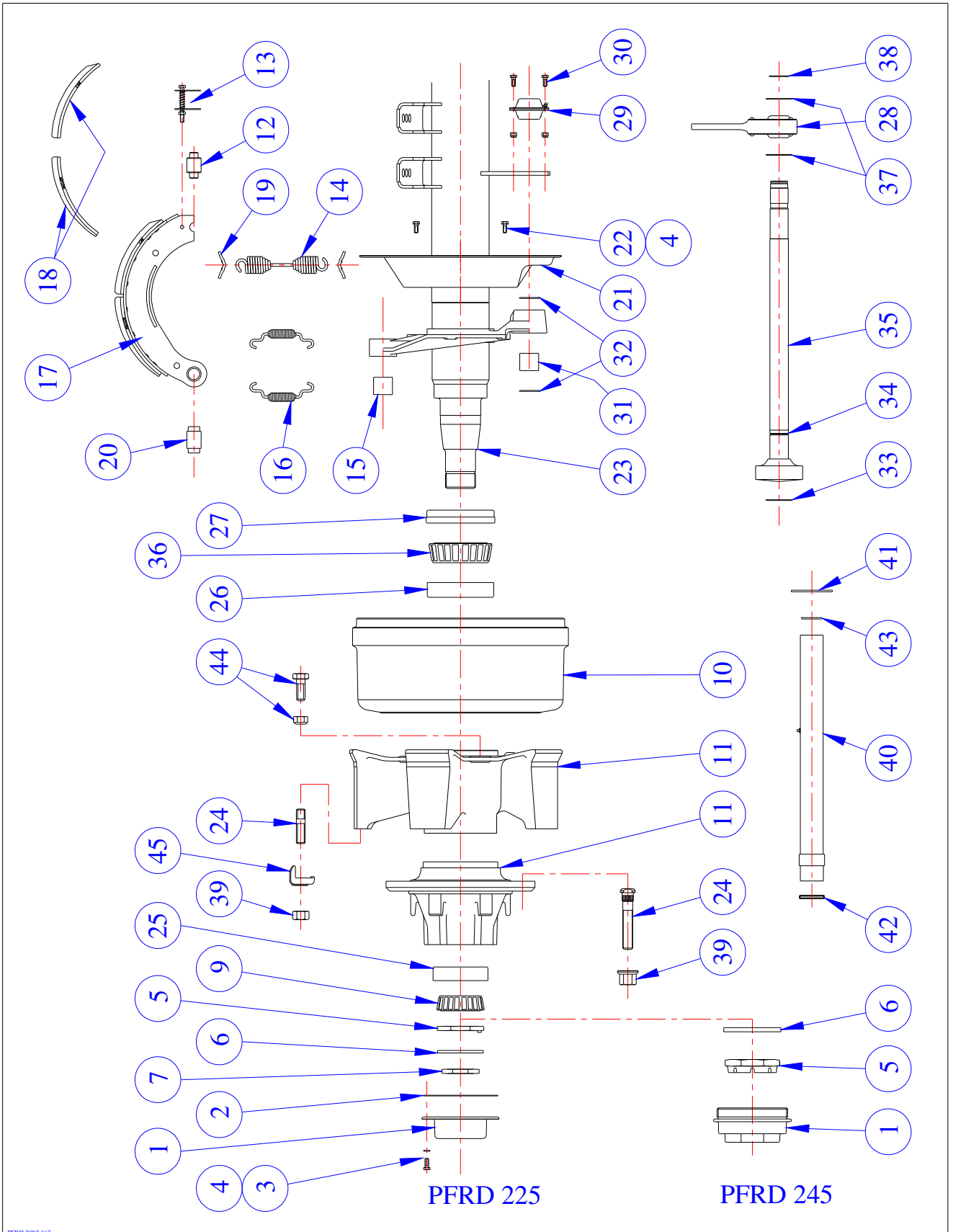

PFRD 2002 167



# TMC Australia Pty Ltd

## TMC Trailer Axle Service Manual - Drum Brakes

### SPARE PARTS - AXLE MODELS PFRD-225-167 and PFRD-245-167

Axles with 420 diameter x 180 wide brakes (16.5" x 7").

Item	Model PFRD-225-167 Part Number	Model PFRD-245-167 Part Number	Description
1	810146	804345	Hub cap – grease
	810176		Hub cap – oil
2	810147		Hub cap gasket
3	9HBM08125020		Hub cap stud M8 x 20 long
4	9SWM08		Spring washer
5	810124	800110	Axle spindle adjusting nut
6	810123	800111	Axle spindle lock washer
7	810125		Axle spindle lock nut
9	81HM212049	800064	Outer bearing cone
10	810110	810153	Brake drum – 5 spoke spider 420x180
	810160	810168	Brake drum – 10 stud x 285 pcd 420x180
	810158	810164	Brake drum – 10 stud x 335 pcd 420x180
11	810108	810151	Hub assembly – 5 spoke spider
	810102	810166	Hub assembly – 10 x 285 ISO steel
	810156	810162	Hub assembly – 10 x 335 ISO steel
	8106395		Hub assembly – 10 x 285 ISO aluminium
	8103416		Hub assembly – 10 x 335 ISO aluminium
12	810094	810094	Cam roller
13	800018	800018	Cam roller retainer
	810093	810093	Cam roller retainer – bolt on
14	800016	800016	Brake return spring
15	800002	800002	Anchor pin bush
16	800015	800015	Brake retainer spring – anchor end
17	800167	800167	Brake shoe lined – Q brake
	810170	810170	Brake shoe lined – P brake
18	810171	810171	Brake lining set inc. rivets
19	800013	800013	Brake return spring retainer pin
20	800014	800014	Anchor pin – Q brake
	810092	810092	Anchor pin – P brake bolt on
21	800003	800003	Dust cover
22	9HBM08125025	9HBM08125025	Dust cover bolt M8 x 25 long
23	Refer TMC	Refer TMC	Axle beam assembly
24	810112	810112	Wheel stud – spider hub
	810225	810225	Wheel stud – M22 ISO x 115mm (long)
	810144	810144	Wheel stud – M22 ISO x 100mm (short)
25	81HM212049	800065	Outer bearing cup
26	81HM218210	800065	Inner bearing cup
27	810135	800723	Hub seal
28	800052	800052	Slack adjuster
29	800001	800001	Inner cam support bushing
30	9HBM10150030	9HBM10150030	Bolt M10 x 30 long
31	800005	800005	Outer cam bushing
32	800032	800032	Camshaft seal
33	810122	810122	Camshaft washer 1 ½"
34	800034	800034	Circlip 1 ½"
35	810117/606L	810117/606L	Camshaft 37 spline - left hand
	810117/606R	810117/606R	Camshaft 37 spline - right hand
36	81HM218248	800064	Inner bearing cone
37	810122	810122	Camshaft washer 1 ¼"
38	810121	810121	Circlip 1 ¼"
39	810113	810113	Wheel nut – spider
	810145	810145	Wheel nut – M22 ISO
40	810206	810206	Enclosed cam tube assembly
41	810201	810201	Enclosed cam tube support plate



# TMC Australia Pty Ltd

## TMC Trailer Axle Service Manual - Drum Brakes

Item	Model PFRD-225-167 Part Number	Model PFRD-245-167 Part Number	Description
42	810208	810208	Enclosed cam tube seal – outer
43	810207	810207	Enclosed cam tube seal – inner
44	810114	810114	Hub drum bolt and conelock nut assy. 3/4"UNF x 2 1/4"
	810169	810169	ABS pole wheel – 100 tooth

### SPARE PARTS - AXLE MODELS PFRD-225-138 and PFRD-245-138

Axles with 335 diameter x 210 wide brakes (13.18" x 8.25").

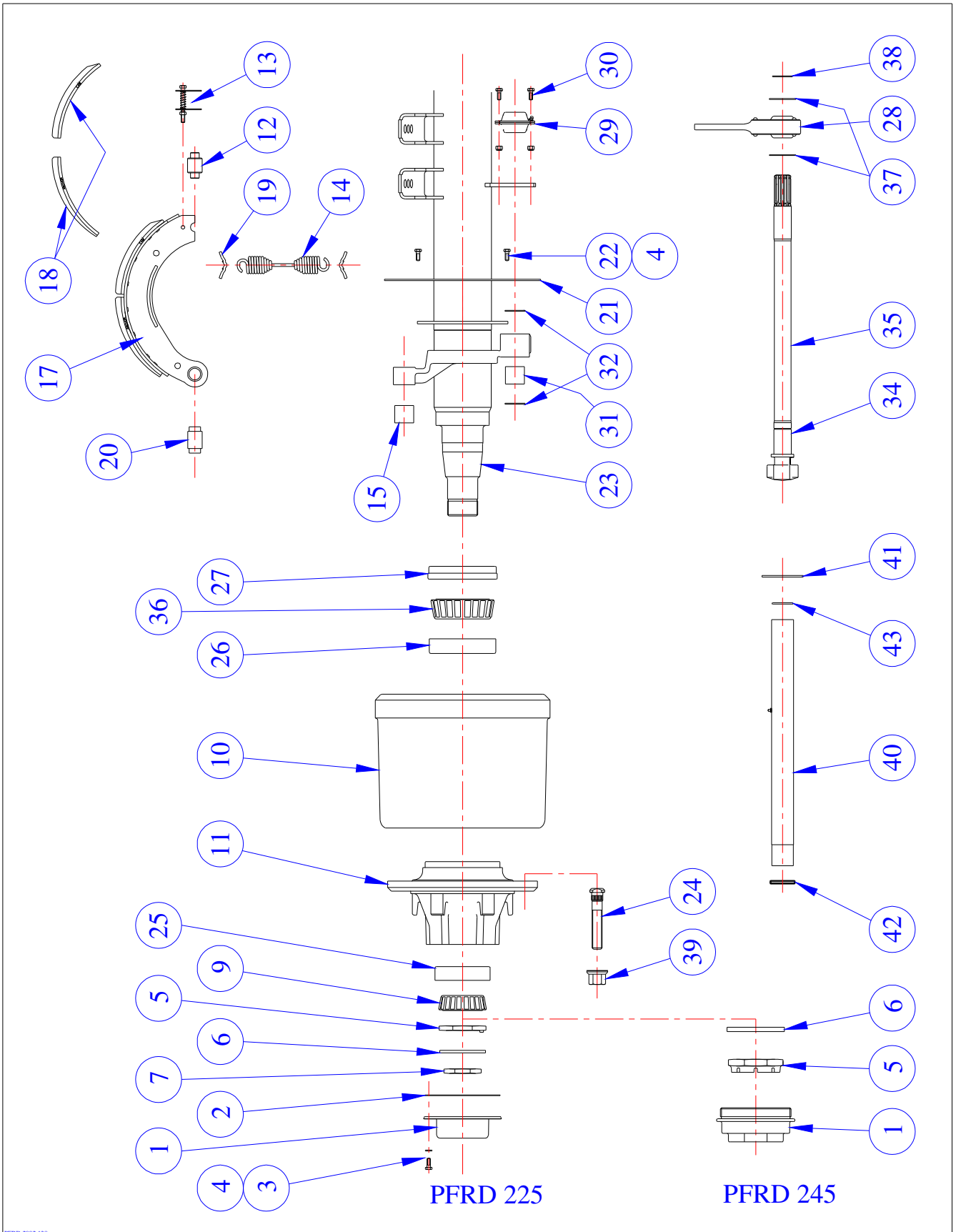

PFRD 2002 138



# TMC Australia Pty Ltd

## TMC Trailer Axle Service Manual - Drum Brakes

### SPARE PARTS - AXLE MODELS PFRD-225-138 and PFRD-245-138

Axles with 335 diameter x 210 wide brakes (13.18" x 8.25").

Item	Model PFRD-225-138 Part Number	Model PFRD-245-138 Part Number	Description
1	810146	804345	Hub cap – grease
	810176		Hub cap – oil
2	810147		Hub cap gasket
3	9HBM08125020		Hub cap stud M8 x 20 long
4	9SWM08		Spring washer
5	810124	800110	Axle spindle adjusting nut
6	810123	800111	Axle spindle lock washer
7	810125		Axle spindle lock nut
9	81HM212049	800064	Outer bearing cone
10	810103	810103	Brake drum – 8 stud x 275 pcd 335x210
	810185		Brake drum – 10 stud x 225 pcd 335x210
11	810177	810179	Hub assembly – 8 x 275 ISO steel
	810188		Hub assembly – 10 x 225 ISO steel
	8106434		Hub assembly – 8 x 275 ISO aluminium
12	810094	810094	Cam roller
13	800018	800018	Cam roller retainer
	810093	810093	Cam roller retainer – bolt on
14	810101	810101	Brake return spring
15	800002	800002	Anchor pin bush
17	810095	810095	Brake shoe lined – P brake
18	810096/810097	810096/810097	Brake lining set inc. rivets
19	800013	800013	Brake return spring retainer pin
20	810092	810092	Anchor pin – P brake bolt on
21	810084	810084	Dust cover
22	9HBM08125025	9HBM08125025	Dust cover bolt M8 x 25 long
23	Refer TMC	Refer TMC	Axle beam assembly
24	810225	810225	Wheel stud – M22 ISO x 115mm (long)
	810144	810144	Wheel stud – M22 ISO x 100mm (short)
25	81HM212011	800065	Outer bearing cup
26	81HM218212	800065	Inner bearing cup
27	810135	800723	Hub seal
28	810120	810120	Slack adjuster
29	800001	800001	Inner cam support bushing
30	9HBM10150030	9HBM10150030	Bolt M10 x 30 long
31	800005	800005	Outer cam bushing
32	800032	800032	Camshaft seal
33	810122	810122	Camshaft washer
35	810105/616L	810105/616L	Camshaft 10 spline - left hand
	810105/616R	810105/616R	Camshaft 10 spline - right hand
36	81HM218248	800064	Inner bearing cone
37	810122	810122	Camshaft washer
38	810121	810121	Camshaft circlip
39	810145	810145	Wheel nut – M22 ISO
40	810091	810091	Enclosed cam tube assembly
41	810087	810087	Enclosed cam tube support plate
42	810081	810081	Enclosed cam tube seal – outer
43	810082	810082	Enclosed cam tube seal – inner
	810169	810169	ABS pole wheel – 100 tooth