

Multi Loader™ 19m B Double

Bulk tipper with side loading capability



- Versatility of a tipper with the added advantage of side opening doors
- Huge load carrying options ranging from woodchip to pallets
- Fitted with a front mounted hoist creating a clear internal loading area

The Forefront of Trailer Technology

LUSTY EMS 

www.lustyems.com.au

Multi Loader™ 19m B Double-Specifications

Configurations	A: Greaseless sliding suspension	B: Chassis Tipper
Bin Lengths	A Trailer	6.38M
	B Trailer	Dependent on prime mover
ALUMINIUM BODY		
Construction	Body construction using Lusty EMS designed extrusions All welding is to the highest standard using water cooled Pulse MIG welders	
Floor	8mm aluminium plate, one piece sheet	
Doors	Double skin aluminium extrusion	
Top Rail	One piece extrusion	
Suspension	Various air bag suspension options available	
Hoist	Front mounted low profile hoist	
Braking System	Dual line ADR approved	
Standard Equipment	<ul style="list-style-type: none"> • Opening side doors, both sides • One way tailgate with grain chute and grain locks with spreader chains • High sides up to 4.3m overall height • Stainless steel weatherproof toolbox • Aluminium 60L water tank • Internal and external steps and ladders • Greaseless turntable • Narva LED multi volt lights rear and sides • Bridgestone 11R 22.5 R285 radials • 2 speed landing legs • Dual tyre carrier 	
Options	<ul style="list-style-type: none"> • Quick release rolltarp with rolled tarp bows - QLD style or Pelemt ends • Painted side doors • Alloy 10 stud wheels • Ballrace turntable • Disc brakes 	
Tare	Approximately 12.5t with alloy wheels, high side and rolltarp	

Multi Loader Tipper (typical dimensions)

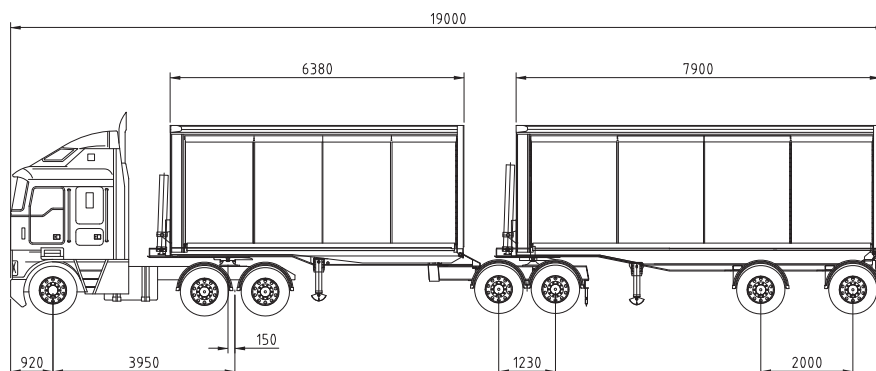

www.lustyems.com.au

See your local Lusty EMS dealer.

Queensland
Head Office
Richlands 07 3375 0000

Victoria
MaxiTRANS Vic Branch
Derrimut 03 8368 1111

Victoria
Mildura Truck Centre
Sunraysia 03 5051 2800
Swan Hill 03 5033 1372

South Australia
Lusty EMS Branch
Wingfield 08 8262 1990

New South Wales
SX Trailers
Sydney 02 9755 3333
Wagga Wagga 02 6921 8377
Newcastle 02 4967 5622

Western Australia
Park Motor Body
Builders
Perth 08 9378 0600

New Zealand
MaxiTRANS
Auckland 09 269 0712

05-2010